

GeneTools MADGE – a new tool for high throughput screening

Introduction to MADGE

MADGE, or Micro Array Diagonal Gel Electrophoresis as it is fully known, is a method invented to serve the need of human molecular genetic epidemiology studies (Day and Humphries 1994: Analytical Biochemistry 222;389-95). MADGE is a simple and highly effective method for high throughput screening. It involves using a 96 well format gel with electrophoresis occurring in a diagonal path, a run length of up to 26.5mm can be achieved. This allows enough separation to calculate molecular weight data and identify doublet bands. 192 and 364 wells format gels are compatible with MADGE and can run simultaneously.

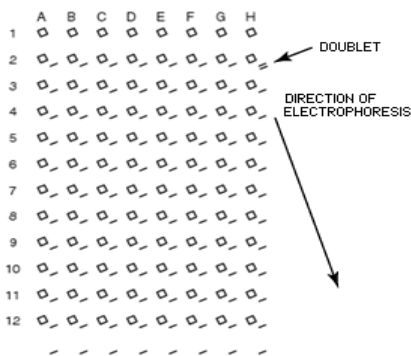

Figure 1: Schematic of MADGE plate set up

Studies which involve a high number of samples to be investigated for mutations such as, single nucleotide polymorphisms (SNP's) requires a very fast system. MADGE offers a high density of wells, reasonable resolution, rapid run times and simplification of sample tracking and identification. MADGE can also be used for investigating both nucleic acids and proteins.

MADGE gels are sold in precast format, and are available in agarose or polyacrylamide. The matrix used is dependent on whether protein or nucleic acid fragments are being separated, and what size they are. The 96 well gel format is commonly used for MADGE were samples can be transferred from microplate to gel simultaneously, using either a 'replicator' (a specially designed 96 pin unit), or a standard 96-way pipettor.

Variations of MADGE include the recently developed MADGE technique, MeltMADGE (a DNA melting-point analysis by microplate array is a high-throughput method of *de novo* scanning for detection of point and frameshift mutations and polymorphisms).

Analysing MADGE with GeneTools software

Due to the diagonal running pattern and very small tracks, it is not possible to analyse MADGE gels using

conventional DNA gel analysis software. Syngene has released a new component of GeneTools that will rapidly and automatically analyse all MADGE gels, regardless of the number of tracks. Like all other functions within GeneTools, MADGE analysis is fully automated, icon driven, can be programmed to suit user preferences and will carry out the entire analysis in a matter of seconds.

MADGE gels are commonly pre or post-stained with Ethidium bromide, Vistra Green, SYBR Green™ etc. However, due to dye deterioration gels stained with the above dyes cannot be stored for any length of time. Image capture may be carried out on any Syngene image capture system fitted with the appropriate filter. For MADGE gels containing more than 96 wells, it is advisable to use a high resolution G:BOX iChemi XR or iChemi XT system for greatly improved image resolution. GeneTools can then be used to analyse and interpret the image.

MADGE gel image analysis using GeneTools software

1. Open a MADGE image in GeneTools software. From the "Sample properties" box select MADGE from the drop down menu

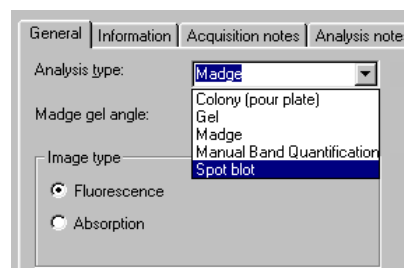

Figure 2: Sample properties box

2. From the Madge gel angle drop down menu select the "degree" of rotation choose either 71.6 or 78.7 degrees.

N.B. The standard angle is 78.7, (13 mm track length) however, the track length can be extended to 26mm by using a lower angle.

3. The direction of electrophoresis and the number of columns and rows can also be programmed. Then click OK.

N.B. The columns and rows refer to the number of defined areas for gels and not the number of MADGE gel columns and rows.

- The gel image will now appear in GeneTools with a track grid placed over the gel image. The grid has four handles, one in each corner (only three of which are active at any one time) which can be used to re-align the track positions.

Fine adjustments can be made to the length, width and position of all tracks or individual tracks.

N.B. if tracks have been positioned individually and then the whole grid is adjusted using the grid handles, the individually placed tracks will revert to their original positions.

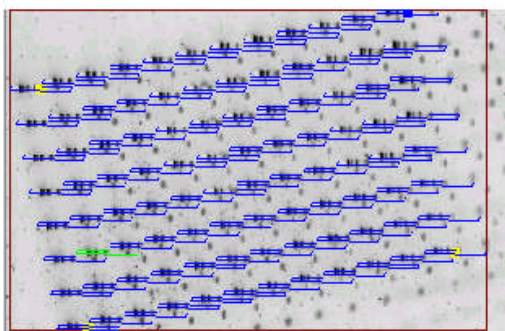

Figure 3: Gel image with track grid

- It is possible to insert new tracks outside the main grid (e.g. molecular weight markers) by double clicking the left mouse button in the centre of the track. These tracks can also be deleted if required; however, none of the 96 tracks in the grid can be removed.
- When all the tracks are positioned they can be locked. The locking operation detects peaks in the tracks and also places the tracks into a horizontally aligned view. It is possible to return to the original view.

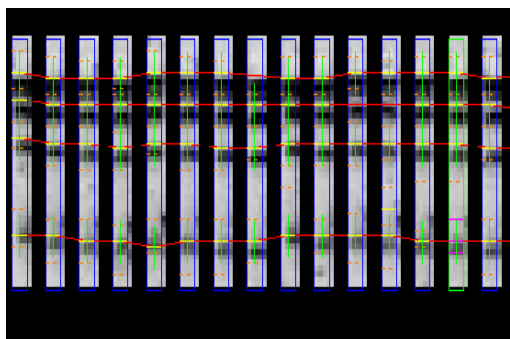

Figure 4: GeneTools view of locked MADGE gel tracks

Once at this stage, analysis can be carried out in the same way as for a conventional electrophoresis gel (please refer to the GeneTools gel analysis quick guide).

Summary

Syngene are leading the way with novel and intuitive software that assists the researcher in obtaining more information from their results in less time.

MADGE analysis from Syngene has a number of advantages over the only competitive product available:

FEATURES	BENEFITS
Analysis of gels with 96, 196 and 384 well formats	Time saving
Programmable peak detection parameters	Improves accuracy
Results can be exported into Microsoft Excel or Word with a single mouse click.	Reporting facilities are comprehensive and GLP compliant
Icon driven and intuitive	Easy to use
Band matching facility	Automatically identifies matching bands according to position, Rf or molecular weight
Link to GeneDirectory software	This database enables the user to carry out complex cluster analysis, track searches and matches

Table 1: GeneTools MADGE software features and benefits

Syngene reserves the right to amend or change specifications without prior notice. This Application Note supersedes all earlier versions.

All trademarks acknowledged.

16.08.09

UK tel: +44 (0)1223 727123
Email: sales@syngene.com

USA tel: 800 686 4407/301 662 2863
Email: ussales@syngene.com